

US009196872B2

(12) **United States Patent**
Son et al.

(10) **Patent No.:** **US 9,196,872 B2**
(45) **Date of Patent:** **Nov. 24, 2015**

(54) **ORGANIC LIGHT-EMITTING DISPLAY APPARATUS AND METHOD OF MANUFACTURING THE SAME**

USPC 257/40, 59, 72; 438/28, 99
See application file for complete search history.

(71) Applicant: **Samsung Display Co., Ltd.**, Yongin, Gyeonggi-Do (KR)

(56) **References Cited**

(72) Inventors: **Jung-Hyun Son**, Yongin (KR); **Kie-Hyun Nam**, Yongin (KR)

U.S. PATENT DOCUMENTS

(73) Assignee: **Samsung Display Co., Ltd.**, Samsung-ro, Giheung-Gu, Yongin-si, Gyeonggi-Do (KR)

7,811,679	B2 *	10/2010	Aziz et al.	428/690
8,258,696	B2	9/2012	Oh et al.	
2001/0043046	A1 *	11/2001	Fukunaga	315/160
2002/0008689	A1 *	1/2002	Koyama et al.	345/100
2005/0046340	A1 *	3/2005	Kohara et al.	313/504
2006/0220549	A1 *	10/2006	Kim et al.	313/512
2007/0200492	A1 *	8/2007	Cok et al.	313/506
2011/0157135	A1	6/2011	Lee et al.	
2011/0163340	A1	7/2011	Smith	
2011/0210348	A1 *	9/2011	Yuasa	257/88

(*) Notice: Subject to any disclaimer, the term of this patent is extended or adjusted under 35 U.S.C. 154(b) by 0 days.

FOREIGN PATENT DOCUMENTS

(21) Appl. No.: **13/873,645**

KR	10-2010-0047367	A	5/2010
KR	10-2011-0036011	A	4/2011
KR	10-2011-0078787	A	7/2011

(22) Filed: **Apr. 30, 2013**

* cited by examiner

(65) **Prior Publication Data**

US 2014/0191203 A1 Jul. 10, 2014

Primary Examiner — Tu-Tu Ho

(30) **Foreign Application Priority Data**

Jan. 10, 2013 (KR) 10-2013-0003141

(74) *Attorney, Agent, or Firm* — Robert E. Bushnell, Esq.

(51) **Int. Cl.**
H01L 51/00 (2006.01)
H01L 51/52 (2006.01)
H01L 27/32 (2006.01)

(57) **ABSTRACT**

(52) **U.S. Cl.**
CPC **H01L 51/5284** (2013.01); **H01L 27/3246** (2013.01); **H01L 51/525** (2013.01); **H01L 51/0024** (2013.01)

Provided is an organic light-emitting display apparatus that includes a display substrate; a plurality of organic light-emitting devices (OLEDs) that are disposed on the display substrate and are separated by a pixel defining layer; an encapsulation substrate that is disposed facing the display substrate and covers the OLEDs; and a filling material that is disposed between the display substrate and the encapsulation substrate and disposed corresponding to the pixel defining layer, wherein the filling material includes a material that absorbs visible light and a method manufacturing the organic light-emitting display apparatus.

(58) **Field of Classification Search**
CPC H01L 51/5284; H01L 51/56; H01L 27/322

23 Claims, 5 Drawing Sheets

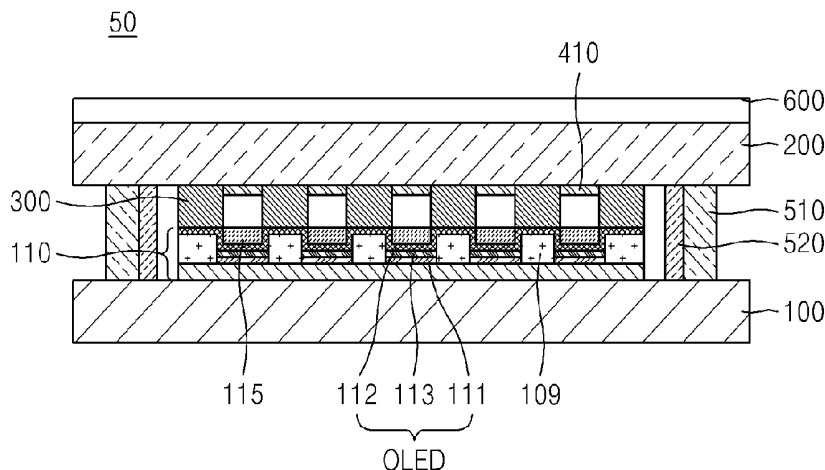

FIG. 1A

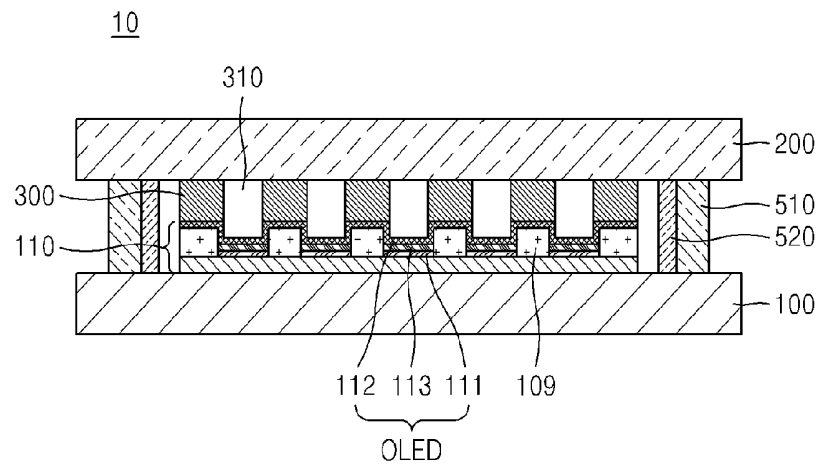

FIG. 1B

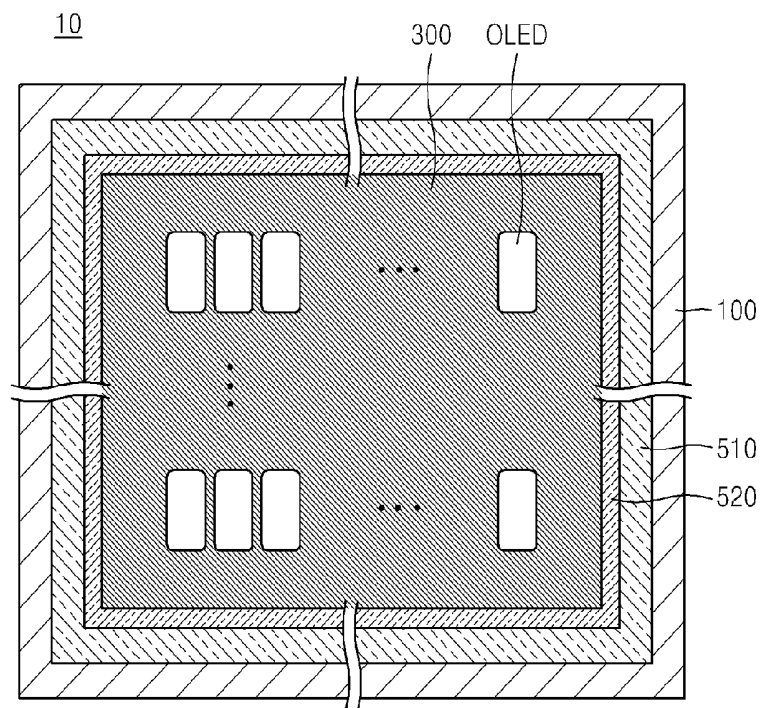

FIG. 2

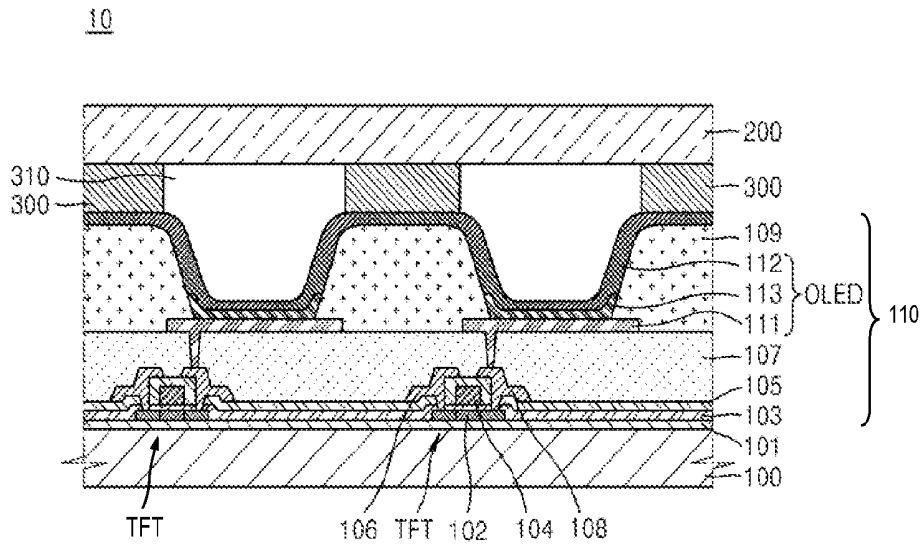

FIG. 3A

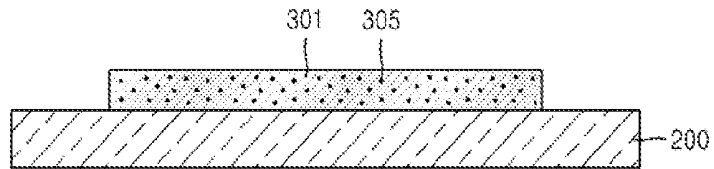

FIG. 3B

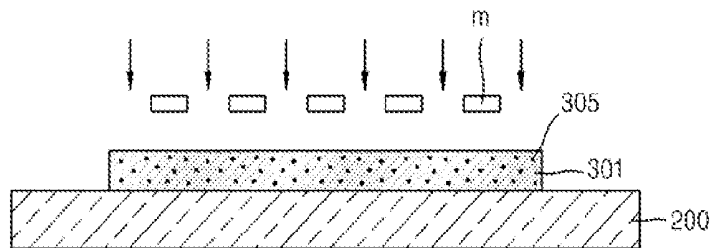

FIG. 3C

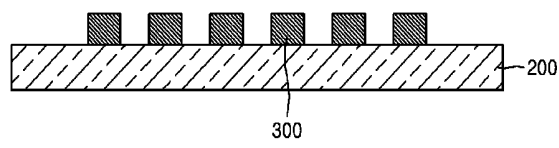

FIG. 3D

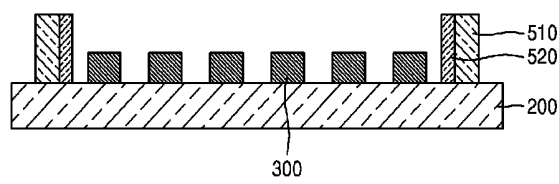

FIG. 3E

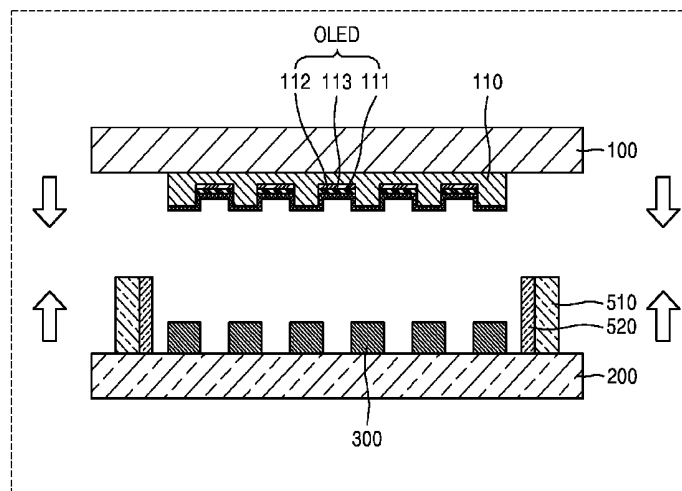

FIG. 4

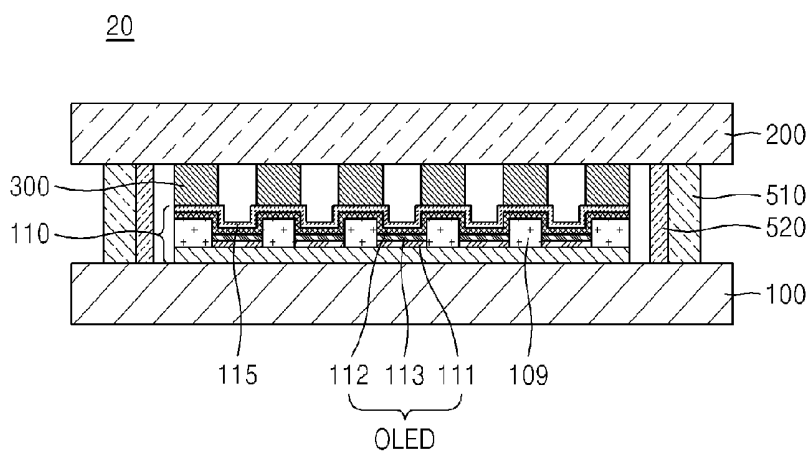

FIG. 5

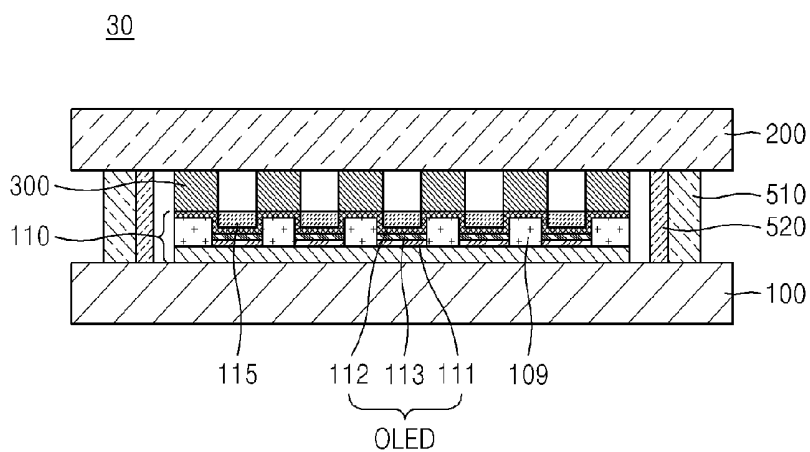

FIG. 6

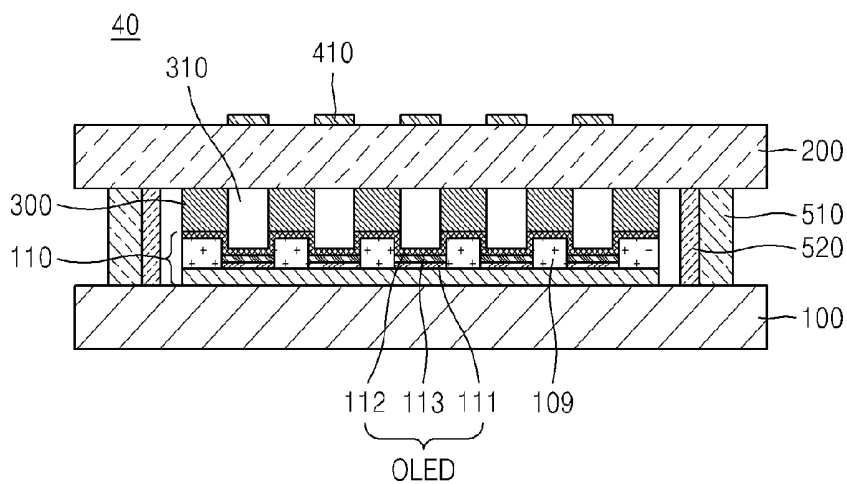
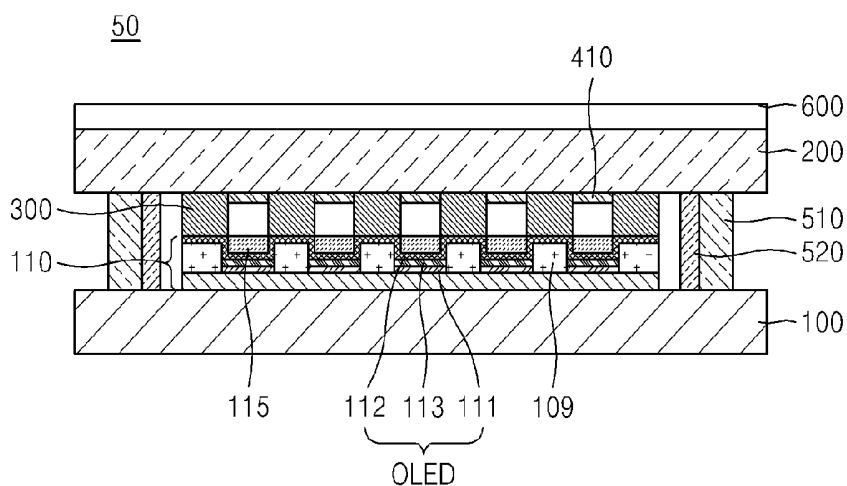

FIG. 7



**ORGANIC LIGHT-EMITTING DISPLAY
APPARATUS AND METHOD OF
MANUFACTURING THE SAME**

CLAIM OF PRIORITY

This application makes reference to, incorporates the same herein, and claims all benefits accruing under 35 U.S.C. § 119 from an application for ORGANIC LIGHT-EMITTING DISPLAY APPARATUS AND METHOD OF MANUFACTURING THE SAME, earlier filed in the Korean Intellectual Property Office on Jan. 10, 2013 and there duly assigned Serial No. 10-2013-0003141.

BACKGROUND OF THE INVENTION

1. Field of the Invention

The present invention relates to an organic light-emitting display apparatus and a method of manufacturing the organic light-emitting display apparatus, and more particularly, to an organic light-emitting display apparatus that includes a filling material and a method of manufacturing the same.

2. Description of the Related Art

An organic light-emitting display apparatus includes a hole injection electrode, an electron injection electrode, and an organic light-emitting device that is formed between the hole injection electrode and the electron injection electrode and includes an organic light-emitting layer. The organic light-emitting display apparatus is an emissive type light-emitting display apparatus that generates light when an energy state of excitons falls from an excited state to a ground state, wherein the excitons are generated by combining holes injected from the hole injection electrode and electrons injected from the electron injection electrode.

An organic light-emitting display apparatus that is an emissive type display apparatus, and thus, an additional light source is not required. Also, the organic light-emitting display apparatus can be driven at a low voltage, can be formed in a light weight and thin film type, and has characteristics of large viewing angle, high contrast, and short response time, and thus, is expected to be a next generation display apparatus.

SUMMARY OF THE INVENTION

The present invention provides an organic light-emitting display apparatus that employs a patterned filling material, and a method of manufacturing the same, and more particularly, to an organic light-emitting display apparatus that can reduce optical loss, can increase contrast, and can strengthen structure, and a method of manufacturing the same.

According to an aspect of the present invention, there is provided an organic light-emitting display apparatus including: a display substrate; a plurality of organic light-emitting devices (OLEDs) that are disposed on the display substrate and are separated by a pixel defining layer; an encapsulation substrate that is disposed facing the display substrate and covers the OLEDs; and a filling material that is disposed between the display substrate and the encapsulation substrate and disposed corresponding to the pixel defining layer, wherein the filling material includes a material that absorbs visible light.

In some embodiment of the present invention, the filling material may include at least one of a black pigment, a black dye, and black particles.

In some embodiment of the present invention, the filling material may include at least one of methyl silicone and phenyl silicone.

In some embodiment of the present invention, the filling material may include at least one selected from the group consisting of Cr, CrO, Graphite, and C.

In some embodiment of the present invention, the organic light-emitting display apparatus may further include a color filter disposed corresponding to the OLED on the encapsulation substrate.

In some embodiment of the present invention, the organic light-emitting display apparatus may further include cavities that are disposed between the display substrate and the encapsulation substrate and may be disposed corresponding to the OLED, wherein the cavities are filled with air or N₂ gas.

In some embodiment of the present invention, the organic light-emitting display apparatus may further include a protective layer disposed on the OLEDs.

In some embodiment of the present invention, the organic light-emitting display apparatus may further include a polarizing layer disposed on the encapsulation substrate.

In some embodiment of the present invention, the organic light-emitting display apparatus may further include an encapsulating member that combines the display substrate with the encapsulation substrate and may be disposed to surround the OLEDs.

In some embodiment of the present invention, the organic light-emitting display apparatus may further include a moisture absorbent disposed on a side of the OLEDs.

According to another aspect of the present invention, there is provided an organic light-emitting display apparatus including: a display substrate; a display unit that is formed on the display substrate and includes a plurality of light-emitting regions on which OLEDs are disposed and non-light-emitting regions that separate the light-emitting regions; an encapsulation substrate that is disposed facing the display substrate; and a filling material that is disposed between the display substrate and the encapsulation substrate and is disposed corresponding to the non-light-emitting regions, wherein the filling material performs as a black matrix that absorbs visible light.

In some embodiment of the present invention, the non-light-emitting regions may protrude more than the light-emitting regions.

In some embodiment of the present invention, the filling material may not be formed on the light-emitting regions.

In some embodiment of the present invention, the filling material may be formed of an insulating material that includes a black pigment, a black dye, or black particles.

In some embodiment of the present invention, the organic light-emitting display apparatus may further include a color filter disposed corresponding to the OLEDs on the encapsulation substrate.

In some embodiment of the present invention, the organic light-emitting display apparatus may further include a protective layer on the OLEDs.

According to an aspect of the present invention, there is provided a method of manufacturing an organic light-emitting display apparatus, the method including: forming a patterned filling material on a surface of an encapsulation substrate; forming a display unit on a surface of a display substrate; and combining the display substrate with the encapsulation substrate with an encapsulating member by disposing the display substrate and the encapsulation substrate so that the display substrate faces the filling material, wherein the filling material comprises at least one of a black pigment, a black dye, and black particles.

In some embodiment of the present invention, the display unit may be divided into light-emitting regions on which OLEDs are disposed and non-light-emitting regions that separate the light-emitting regions, and the filling material may be patterned to be disposed only on regions of the display unit corresponding to the non-light-emitting regions.

In some embodiment of the present invention, the filling material may include at least one of methyl silicone and phenyl silicone.

In some embodiment of the present invention, the filling material may include at least one selected from the group consisting of Cr, CrO, Graphite, and C.

In some embodiment of the present invention, the forming of the patterned filling material may include: distributing at least one of a black pigment, a black dye, and black particles in a liquid phase filling material; coating the liquid phase filling material on the encapsulation substrate; and patterning the filling material through an exposure and developing process.

In some embodiment of the present invention, the method may further include hardening the liquid phase filling material.

In some embodiment of the present invention, the combining of the display substrate with the encapsulation substrate may further include: coating the encapsulating member to surround edges of the filling material; and combining the display substrate with the encapsulation substrate by using the encapsulating member in a vacuum state by disposing the display substrate and the encapsulation substrate so that the display substrate faces the filling material.

In some embodiment of the present invention, the display unit may be divided into light-emitting regions on which OLEDs are disposed and non-light-emitting regions that separate the light-emitting regions, and the method may further include forming a color filter in regions of the encapsulation substrate that corresponds to the light-emitting regions.

In some embodiment of the present invention, the method may further include forming a moisture absorbent between the encapsulation member and the filling material before combining the display substrate with the encapsulation substrate.

The organic light-emitting display apparatus according to the present invention includes the filling material that performs as a black matrix, and thus, the structural strength of the organic light-emitting display apparatus may be increased and, at the same time, color definition and contrast are increased.

Also, the filling material is formed on the non-light-emitting regions of the organic light-emitting display apparatus, and thus, the structural strength of the organic light-emitting display apparatus may be increased and, at the same time, the loss of light emitted from the light-emitting regions due to the filling material may be prevented since the filling material is not formed on the light-emitting regions.

Since the filling material is not formed in the light-emitting regions of the organic light-emitting display apparatus, the occurrence of dark spots due to the filling material may be prevented.

BRIEF DESCRIPTION OF THE DRAWINGS

The above and other features and advantages of the present invention will become more apparent by describing in detail exemplary embodiments thereof with reference to the attached drawings in which:

FIG. 1A is a schematic cross-sectional view of an organic light-emitting display apparatus according to an embodiment of the present invention;

FIG. 1B is a schematic plan view of the organic light-emitting display apparatus of FIG. 1A;

FIG. 2 is a schematic cross-sectional view showing a portion of the organic light-emitting display apparatus of FIG. 1A;

FIGS. 3A through 3E are schematic cross-sectional views showing a method of manufacturing an organic light-emitting display apparatus of FIG. 1A, according to an embodiment of the present invention;

FIG. 4 is a schematic cross-sectional view of an organic light-emitting display apparatus according to another embodiment of the present invention;

FIG. 5 is a schematic cross-sectional view of an organic light-emitting display apparatus according to another embodiment of the present invention;

FIG. 6 is a schematic cross-sectional view of an organic light-emitting display apparatus according to still another embodiment of the present invention; and

FIG. 7 is a schematic cross-sectional view of an organic light-emitting display apparatus according to yet another embodiment of the present invention.

DETAILED DESCRIPTION OF THE INVENTION

Hereafter, the present invention will be described more fully with reference to the accompanying drawings of FIGS. 1 to 7. In the drawings, like reference numerals denote like elements and thus, the descriptions thereof will not be repeated. Also, in the drawings, lengths and sizes of layers and regions may be exaggerated for clarity.

The invention described below is exemplary, and thus, may be embodied in many different forms. For example, when an element or layer is referred to as being "on" another element or layer, the element or layer may be directly on another element or layer or intervening elements or layers.

The terminologies used herein are for the purpose of describing particular embodiments only and is not intended to be limiting of the inventive concept. As used herein, the singular forms are intended to include the plural forms as well, unless the context clearly indicates otherwise. It will be further understood that the terms: "comprise" and/or "comprising," when used in this specification, specify the presence of stated features, steps, operations, and/or components, but do not preclude the presence or addition of one or more other features, steps, operations, and/or components, and/or groups thereof. It will be understood that, although the terms first, second, third, etc., may be used herein to describe various elements, these elements should not be limited by these terms, and the terms are used for the purpose of distinguishing an element from another element.

It should be understood that when an embodiment is able to be embodied in a different form, the sequence of a specific process may be performed in a sequence different from the sequence described. For example, two processes consecutively described may be simultaneously performed, or may be performed in a reversed sequence.

FIG. 1A is a schematic cross-sectional view of an organic light-emitting display apparatus 10 according to an embodiment of the present invention. FIG. 1B is a schematic plan view of the organic light-emitting display apparatus 10 of FIG. 1A. FIG. 2 is a schematic cross-sectional view showing a portion of the organic light-emitting display apparatus 10 of FIG. 1A.

Referring to FIGS. 1A, and 1B, and FIG. 2, the organic light-emitting display apparatus **10** may include a display substrate **100**, a display unit **110**, an encapsulation substrate **200**, and a filling material **300**. Also, the organic light-emitting display apparatus **10** may further include at least one of an encapsulating member **510** or a moisture absorbent **520**.

The display substrate **100** may be formed of a transparent glass material having SiO_2 as a main component. The display substrate **100** according to the present invention is not limited thereto, that is, may be formed of a transparent plastic material. The plastic material to be used for forming the display substrate **100** may be an insulating organic material selected from the group consisting of polyethersulphone (PES), polyacrylate (PAR), polyetherimide (PEI), polyethylenenaphthalate (PEN), polyethyleneterephthalate (PET), polyphenylenesulfide (PPS), polyallylate, polyimide, polycarbonate (PC), cellulotriacetate (TAC), and celluloseacetatepropionate (CAP).

In the case of a bottom emission type organic light-emitting display apparatus in which an image is realized in a direction towards the display substrate **100**, the display substrate **100** may be formed of a transparent material. However, in the case of a top emission type organic light-emitting display apparatus in which an image is realized in a direction opposite to the display substrate **100**, the display substrate **100** may not be necessarily formed of a transparent material and may be formed of ceramic or a metal material. For example, the display substrate **100** may include at least one material selected from the group consisting of carbon, iron, chrome, manganese, nickel, titanium, molybdenum, and stainless steel (SUS), but not limited thereto. The display substrate **100** may use a substrate formed of a metal foil.

An auxiliary layer **101** (not shown in Figures) such as a bearing layer, a blocking layer, and/or a buffer layer for preventing diffusion of impurity ions, preventing penetration of moisture or external air, and for planarizing a surface may be formed on an upper surface of the display substrate **100**. The auxiliary layer **101** may be formed of SiO_2 and/or SiN_x and/or SiO_xN_y . The auxiliary layer **101** may be formed by using various deposition methods, such as a plasma enhanced chemical vapor deposition (PECVD) method, an atmospheric pressure CVD (APCVD) method, or a low pressure CVD (LPCVD) method. The auxiliary layer **101** is not a requisite layer, and accordingly, may be omitted if unnecessary.

The display unit **110** may be disposed on an upper surface of the display substrate **100** and may include thin film transistors (TFTs) and organic light-emitting devices (OLEDs). In FIG. 2, a TFT is formed on each of pixels for convenience of explanation. However, the present invention is not limited thereto, that is, a plurality of TFTs and storage capacitors may further be included in each of the pixels.

The TFTs drive the OLEDs by being electrically connected to the OLEDs. The TFTs depicted in FIG. 2 are top gate type TFTs and the top gate type TFT may include an active layer **102**, a gate electrode **104**, a source electrode **106**, and a drain electrode **108** in the stated order from the display substrate **100**. In FIG. 2, top gate type TFTs are depicted. However, the present invention is not limited to the top gate type TFTs, and thus, it should be understood by those ordinary skilled in the art that the present invention may employ various types of TFTs.

The active layer **102** may be formed by patterning an inorganic semiconductor layer, such as silicon or an oxide semiconductor, or an organic semiconductor layer after forming the inorganic semiconductor layer or an organic semiconductor layer on a whole surface of the auxiliary layer **101** or on the display substrate **100**.

In another embodiment, the active layer **102** may be formed of amorphous silicon. In this case, after forming amorphous silicon on a whole surface of the display substrate **100**, a polycrystalline silicon layer may be formed by crystallizing the amorphous silicon and the polycrystalline silicon layer is patterned. Afterwards, a source region and a drain region may be formed on edge regions of the active layer **102** by doping a dopant in the source region and the drain region, and the active layer **102** that includes a channel region may be formed between the source region and the drain region.

In another embodiment, the active layer **102** may be formed of an oxide semiconductor. For example, the oxide semiconductor may include an oxide selected from the group consisting of a metal element of group **12**, **13**, and **14**, such as Zn, In, Ga, Sn, Cd, Ge, Hf, and combinations of these materials.

The source region and the drain region may be formed on edge regions of the active layer **102**, and the source region and the drain region may be respectively connected to a source electrode **106** and a drain electrode **108**. A gate insulating layer **103** may be formed on the active layer **102**, and a gate electrode **104** may be formed on a predetermined region of an upper surface of the gate insulating layer **103**. The gate electrode **104** may be connected to a gate line (not shown) that applies an ON/OFF signal to the TFT.

An interlayer insulating layer **105** is formed on the gate electrode **104**, and the source electrode **106** and the drain electrode **108** are respectively formed to be connected to the source region and the drain region of the active layer **102**.

The gate insulating layer **103** and the interlayer insulating layer **105** may be formed of an insulating material. For example, the gate insulating layer **103** and the interlayer insulating layer **105** may be formed to be a single-layered or a multi-layered structure of an inorganic material, an organic material, or a composite of an organic material and an inorganic material. In the current embodiment, the gate insulating layer **103** and the interlayer insulating layer **105** may be formed by including SiN_x or SiO_2 .

A planarizing layer **107** may protect the TFT by covering the TFT and/or may planarize an upper surface of the TFT by removing a step difference of the TFT in order to increase light-emitting efficiency of an organic light-emitting device to be formed on the planarizing layer **107**. The planarizing layer **107** may be formed of an inorganic insulating layer and/or an organic insulating layer. The inorganic insulating layer may be formed including at least one of SiO_2 , SiN_x , SiON , Al_2O_3 , TiO_2 , Ta_2O_5 , HfO_2 , ZrO_2 , BST, and PZT, and the organic insulating layer may be formed including at least one material selected from the group consisting of poly(methylmethacrylate) (PMMA), polystyrene (PS), a polymer derivative having a phenol group, an acryl group polymer, an imide group polymer, an arylester group polymer, an amide group polymer, a fluoride group polymer, a p-glyrene group polymer, a vinyl alcohol group polymer, and a blend of these materials. Also, the planarizing layer **107** may be formed of a composite stack layer of the inorganic insulating layer and the organic insulating layer.

The OLEDs are formed in the light-emitting regions of an upper surface of the planarizing layer **107**. The light-emitting regions and the non-light-emitting regions will be described below when a pixel defining layer **109** is described.

Each of the OLEDs includes an anode electrode **111** connected to one of the source electrode **106** and the drain electrode **108** of the TFT, a cathode electrode **112** formed facing the anode electrode **111**, and an organic light-emitting layer **113** interposed between the anode electrode **111** and the cathode electrode **112**.

The anode electrode **111** of the OLED is formed on the planarizing layer **107**, and the pixel defining layer **109** covering the anode electrode **111** is formed by using an insulating material. The pixel defining layer **109** may be formed by including a resin, such as polyacrylates, polyimides, benzocyclobutene, or phenol and an inorganic material of a silica group. In the current embodiment, the pixel defining layer **109** may be formed by using a spin coating method.

After forming a predetermined opening that exposes a central region of the anode electrode **111** in the pixel defining layer **109**, the organic light-emitting layer **113** of the OLED may be formed in a region defined as the opening. Afterwards, the cathode electrode **112** of the OLED is formed to cover the entire pixel defining layer **109** and the organic light-emitting layer **113**.

A sub-pixel may be defined by the opening of the pixel defining layer **109**, and one OLED is disposed in each of the sub-pixels. That is, light-emitting regions are formed in the opening of the pixel defining layer **109** due to the formation of the organic light-emitting layer **113**, and the light-emitting regions are separated by the pixel defining layer **109**. Also, the pixel defining layer **109** may be defined as non-light-emitting regions.

The anode electrode **111** may be a transparent electrode or a reflective electrode. When the anode electrode **111** is a transparent electrode, the anode electrode **111** may be formed of a material selected from the group consisting of ITO, IZO, ZnO, and In₂O₃, and when the anode electrode **111** is a reflective electrode, the anode electrode **111** may include a reflective film formed of a material selected from the group consisting of Ag, Mg, Al, Pt, Pd, Au, Ni, Nd, Ir, Cr, and a compound of these materials and a transparent film formed of a material selected from the group consisting of ITO, IZO, ZnO, and In₂O₃. In the current embodiment, the anode electrode **111** may be a reflective electrode having an ITO/Ag/ITO structure.

The cathode electrode **112** may also be a transparent electrode or a reflective electrode. When the cathode electrode **112** is a transparent electrode, the cathode electrode **112** may include a layer formed to face the organic light-emitting layer **113** by depositing a material selected from the group consisting of Li, Ca, LiF/Ca, LiF/Al, Al, Mg, and a compound of these materials and an auxiliary electrode or a bus electrode line formed of a transparent conductive material selected from the group consisting of TO, IZO, ZnO, and In₂O₃ on the layer. When the cathode electrode **112** is a reflective electrode, the cathode electrode **112** may be formed of a material selected from the group consisting of Li, Ca, LiF/Ca, LiF/Al, Al, Mg, and a compound of these materials. In the current embodiment, the anode electrode **111** and the cathode electrode **112** may be reversed.

The organic light-emitting layer **113** included between the anode electrode **111** and the cathode electrode **112** may be formed of a low molecular weight organic material or a polymer organic material. When the organic light-emitting layer **113** is formed of a low molecular weight organic material, a hole injection Layer (HIL) (not shown), a hole transport layer (HTL) (not shown), an electron transport layer (ETL) (not shown), or an electron injection layer (EIL) (not shown) may be stacked in a single or composite stack structure by disposing the organic light-emitting layer **113** therebetween. The organic light-emitting layer **113** may be formed of various materials including copper phthalocyanine (CuPc), N,N'-di(naphthalene-1-yl)-N,N'-diphenyl-benzidine (NPB), or tris-8-hydroxyquinoline aluminium (Alq3). The low molecular organic material may be formed by using a vacuum evaporation method.

When the organic light-emitting layer **113** is formed of a polymer organic material, a structure in which a hole transport layer (HIL) (not shown) is further formed towards the anode electrode **111** from the organic light-emitting layer **113** may be formed. At this point, the HTL may be formed of poly-(2,4)-ethylene-dihydroxy thiophene (PEDOT), and the organic light-emitting layer **113** may be formed of a polymer organic material, such as a poly-phenylenevinylene (PPV) group material or a polyfluorene group material. The organic light-emitting layer **113** formed in this way may emit one of red, green, and blue light.

Also, in FIG. 2, the organic light-emitting layer **113** is disposed only in the opening of the pixel defining layer **109**. However, the present disclosure is not limited thereto. For example, the organic light-emitting layer **113** may be formed on the anode electrode **111** in the opening of the pixel defining layer **109** and may also be disposed between the pixel defining layer **109** and the cathode electrode **112**.

In the embodiment described above, different light-emitting materials are formed in each of the sub-pixels by forming the organic light-emitting layers **113** in the openings, but the present disclosure is not limited thereto. That is, the organic light-emitting layer **113** may be commonly formed on the whole planarizing layer **107** regardless of the locations of the sub-pixels. At this point, the organic light-emitting layer **113** may be formed by vertically stacking or mixing layers that include light-emitting materials that emit, for example, red, green, or blue light. Of course, if the organic light-emitting layer **113** may emit white light, the organic light-emitting layer **113** may also emit a combination of different colors.

The display unit **110** that is used in the current embodiment includes the TFTs and the OLEDs formed on the display substrate **100**. Accordingly, the display unit **110** includes a plurality of light-emitting regions in which the OLEDs are disposed and the non-light-emitting regions which are protruded pixel defining layers **109** that separate the plural light-emitting regions.

The encapsulation substrate **200** is disposed facing the display substrate **100**. The encapsulation substrate **200** blocks the display unit **110** that includes the OLEDs from external moisture and air. The encapsulation substrate **200** may use not only a glass material display substrate **100** but also various plastic material substrates, and furthermore, may use a metal plate. In the current embodiment, a polarizing layer or a color conversion layer may further be formed on the encapsulation substrate **200**.

The filling material **300** is disposed between the display substrate **100** and the encapsulation substrate **200**, and is disposed corresponding to the pixel defining layer **109** on the pixel defining layer **109**. That is, the filling material **300** is disposed corresponding to the non-light-emitting regions on the pixel defining layer **109**. The filling material **300** may not be disposed on the light-emitting regions that are defined by the OLEDs. However, the present disclosure is not limited thereto, that is, the filling material **300** may be disposed on the OLEDs. In the current embodiment, the filling material **300** is patterned to be remained on the non-light-emitting regions. Referring to FIG. 1A, the filling material **300** may be patterned in a mesh shape to the encapsulation substrate **200** to surround the light-emitting regions.

The filling material **300** protects the display unit **110** from impact that may be applied from the outside. Also, the filling material **300** may absorb visible light incident from the outside, may prevent a color mix or interference of visible light emitting through the OLEDs, and may increase contrast of the organic light-emitting display apparatus **10**. That is, the filling material **300** performs as a black matrix.

The filling material **300** may be formed of an insulating material. In the current embodiment, the filling material **300** may include at least one of methyl silicone and phenyl silicone. In the current embodiment, the filling material **300** may be polyimide. However the present disclosure is not limited thereto, that is, the filling material **300** may be formed of a material selected from the group consisting of a urethane group resin which is an organic sealant, an epoxy group resin, an acryl group resin, and silicon which is an inorganic sealant.

When the filling material **300** is formed of thermally stable silicon, the filling material **300** may not be degraded by heat generated during an operation of the organic light-emitting display apparatus **10**. Also, the filling material **300** may not be degraded by heat when the display substrate **100** and the encapsulation substrate **200** are combined by using heat.

The filling material **300** may include a material that absorbs visible light. The filling material **300** may include at least one of a black dye, a black pigment, and black particles. In the current embodiment, the filling material **300** may include Cr or CrOx, Cr/CrOx, Cr/CrOx/CrNy, a resin (carbon pigment or RGB mixed pigment), graphite, or non-Cr group material.

Cavities **310** are disposed corresponding to the OLEDs above the OLEDs. In the current embodiment, the cavities **310** may be filled with air or an N₂ gas, or may be a vacuum state.

The encapsulating member **510** is disposed to surround the display unit **110**, and may combine the display substrate **100** with the encapsulation substrate **200**. The encapsulating member **510** blocks the display unit **110** that includes the OLEDs from external moisture and air. The encapsulating member **510** may be formed of a conventional material such as sealing glass or frit.

The moisture absorbent **520** may be disposed on a side of the display unit **110**. The moisture absorbent **520** may prevent the OLEDs from reducing lifetime due to moisture or oxygen by readily reacting with the moisture or oxygen. The moisture absorbent **520** may be formed of a material selected from the group consisting of alkaline metal oxide, alkaline earth metal oxide, metal halide, lithium sulfate, metal sulfate, metal perchlorate, silica gel, phosphorus pentoxide, and a mixture of these materials. The type and disposition of the moisture absorbent **520** according to the present disclosure are not limited to the above descriptions.

Although not shown, the organic light-emitting display apparatus **10** may further include a conductive layer (not shown) between the non-light-emitting regions and the filling material **300**. The conductive layer may reduce a resistance and prevent a voltage drop of the cathode electrode **112** by being electrically connected to the cathode electrode **112** of the OLED. The conductive layer may be formed of a material selected from the group consisting of Li, Ca, LiF/Ca, LiF/Al, Al, Mg, and Ag. Besides above, a protective layer for protecting the OLEDs may further be included in the organic light-emitting display apparatus **10**.

As described above, the organic light-emitting display apparatus **10** according to the current embodiment includes a filling material **300** that performs as a black matrix, and thus, the structural strength of the organic light-emitting display apparatus **10** is increased and, at the same time, color definition and contrast are increased.

In the organic light-emitting display apparatus **10** according to the current embodiment, the filling material **300** may not be disposed on the OLEDs which are light emitting regions or a small amount is disposed on the OLEDs. Therefore, optical loss due to the disposition of the filling material

300 may be prevented and the occurrence of dark spots due to the presence of the filling material **300** may be reduced.

Also, in the light-emitting region of the organic light-emitting display apparatus **10**, the cavities **310** are formed on the OLEDs, and thus, damage to the OLEDs due to particles may be prevented.

FIGS. 3A through 3E are schematic cross-sectional views showing a method of manufacturing the organic light-emitting display apparatus **10** of FIG. 1A, according to an embodiment of the present disclosure.

Referring to FIG. 3A, a liquid phase filling material **301** is coated on a surface of the encapsulation substrate **200**. The liquid phase filling material **301** may include a black material **305**, for example, at least one of a black pigment, a black dye, and black particles. The black material **305** may be mixed in the liquid phase filling material **301** before or after coating the liquid phase filling material **301** on the surface of the encapsulation substrate **200**.

In the current embodiment, the liquid phase filling material **301** may be silicon. More specifically, the liquid phase filling material **301** may be methyl silicone, phenyl silicone, or a mixture of these materials. In the current embodiment, the liquid phase filling material **301** may be liquid phase polyimide. Here, the liquid phase polyimide denotes a state that polyimide is dissolved in an organic solvent that performs a diluent and has flowability.

The liquid phase filling material **301** may be coated by a spin coating process, a slit coating process, or a gravure process. Since the liquid phase filling material **301** has flowability, planarity is good after coating it, and thus, product failure due to a step difference may be reduced.

Next, the liquid phase filling material **301** may be softly baked at a low temperature. The soft baking may be a process of reducing flowability by semi-hardening or semi-drying the liquid phase filling material **301** to remove some portion of an organic solvent included in the liquid phase filling material **301**.

Referring to FIGS. 3B and 3C, the semi-hardened or semi-dried liquid phase filling material **301** is patterned by using a mask **m**. That is, the liquid phase filling material **301** is exposed to light after aligning the liquid phase filling material **301** with a desired shape of mask to harden and develop the liquid phase filling material **301**, and thus, the liquid phase filling material **301** is patterned. Here, the process of patterning according to the current embodiment is not limited to the process described with reference to FIGS. 3B and 3C, that is, the liquid phase filling material **301** in the exposed region may be removed, and the liquid phase filling material **301** in the region that is not exposed may remain. That is, the patterning process is similar to a general photolithography process, and thus, the detailed description will be omitted.

The liquid phase filling material **301** may become a solid phase filling material **300** by the exposing to light. Also, a hardening process may further be included after the patterning. The liquid phase filling material **301** may be hardened to a solid state by an optical hardening method, a thermal hardening method, an acid hardening method, or a combination of these methods according to the material of the liquid phase filling material **301**. In the current embodiment, the liquid phase filling material **301** may be hardened by vaporizing the solvent at a high temperature. For example, the hardening temperature may be in a range from about 200° C. to about 300° C.

Next, referring to FIG. 3D, the encapsulating member **510** and the moisture absorbent **520** are formed vertically on the encapsulation substrate **200** to surround the solid phase filling material **300**. At this point, the encapsulating member **510**

may be formed by coating a liquid phase or paste state encapsulating material, and the moisture absorbent **520** may be formed by coating a liquid phase moisture absorbent material.

Referring to FIG. 3E, the display substrate **100** on which the display unit **110** including the TFTs, and the OLEDs are formed is combined with the encapsulation substrate **200**. At this point, the display substrate **100** and the encapsulation substrate **200** are disposed so that the display unit **110** faces the solid phase filling material **300**. In the current embodiment, the display substrate **100** and the encapsulation substrate **200** may be combined in a vacuum state. When the display substrate **100** is combined with the encapsulation substrate **200** in a vacuum state, the penetration of external moisture and foreign materials may be reduced. The display substrate **100** and the encapsulation substrate **200** are bonded by using the encapsulating member **510**. In the current embodiment, the combining of the display substrate **100** with the encapsulation substrate **200** may be completed by melting a surface of the encapsulating member **510** that contacts the display substrate **100** and/or the encapsulation substrate **200** by irradiating ultraviolet rays to the encapsulating member **510** that corresponds to the display substrate **100** and/or the encapsulation substrate **200**. However, the above method is an exemplary, that is, the display substrate **100** and the encapsulation substrate **200** may be combined in various ways according to the kinds of the encapsulating member **510**.

FIG. 4 is a schematic cross-sectional view of an organic light-emitting display apparatus **20** according to another embodiment of the present disclosure. In FIG. 4, like reference numerals denote like elements in FIG. 1, and thus, descriptions thereof will be omitted.

Referring to FIG. 4, the organic light-emitting display apparatus **20** further includes a protective layer **115** on the cathode electrode **112** when compared to the organic light-emitting display apparatus **10** of FIG. 1. In FIG. 4, the protective layer **115** covers both the light-emitting regions and the non-light emitting regions, but the present invention is not limited thereto. The protective layer **115** may only cover the light-emitting regions, i.e. the OLEDs. The protective layer **115** may be an inorganic insulating layer and/or an organic insulating layer. The inorganic insulating layer may be formed including a material selected from the group consisting of SiO₂, SiN_x, SiON, Al₂O₃, TiO₂, Ta₂O₅, HfO₂, ZrO₂, BST, and PZT. The organic insulating layer may be formed including at least one material selected from the group consisting of poly(methylmethacrylate) (PMMA), polystyrene (PS), a polymer derivative having a phenol group, an acryl group polymer, an imide group polymer, an arylester group polymer, an amide group polymer, a fluoride group polymer, a p-glyrene group polymer, a vinyl alcohol group polymer, and a blend of these materials. The protective layer **115** may be deposited by using various deposition methods, such as a plasma enhanced chemical vapor deposition (PECVD) method, an atmospheric pressure CVD (APCVD) method, or a low pressure CVD (LPCVD) method.

FIG. 5 is a schematic cross-sectional view of an organic light-emitting display apparatus **30** according to another embodiment of the present disclosure. In FIG. 5, like reference numerals denote like elements in FIG. 4, and thus, descriptions thereof will be omitted.

Referring to FIG. 5, when the organic light-emitting display apparatus **30** is compared with the organic light-emitting display apparatus **20** of FIG. 4, there is a difference in that the protective layer **115** is formed to cover the light-emitting regions being parallel to a protrusion unit of the non-light-emitting region. The thickness of the protective layer **115** may be variously changed in consideration of optical loss and pro-

tection of the OLEDs. Although, it is depicted that the protective layer **115** is formed in the light-emitting region in FIG. 5, the present disclosure is not limited thereto. That is, the protective layer **115** may be formed both in the light-emitting region and the non-light emitting region with planarity.

FIG. 6 is a schematic cross-sectional view of an organic light-emitting display apparatus **40** according to still another embodiment of the present disclosure. In FIG. 6, like reference numerals denote like elements in FIG. 1, and thus, descriptions thereof will be omitted.

Referring to FIG. 6, when the organic light-emitting display apparatus **40** is compared with the organic light-emitting display apparatus **10** of FIG. 1, the organic light-emitting display apparatus **40** further includes color filters **410**.

The color filters **410** are disposed corresponding to the OLEDs that define the light-emitting regions. The color filters **410** may be formed to realize a full-color image, to increase in color purity, and to increase ambient contrast ratio (ACR). In the drawing, the color filters **410** may be formed on an upper surface of the encapsulation substrate **200**, but the present disclosure is not limited thereto. For example, the color filters **410** may be formed on a lower surface of the encapsulation substrate **200** or may be formed in contact with the OLEDs.

The color filters **410** may extract light corresponding to a predetermined color from light emitted from the organic light-emitting layer **113** in the OLED. The color filters **410** may realize various colors according to the OLEDs that correspond to the color filters **410**. In the current embodiment, the color filters **410** may realize one of red, green, and blue color. In the current embodiment, the color filters **410** may realize a color of a wavelength band of light emitted from the OLEDs. For example, the color filters **410** that realize blue color may be disposed on the OLEDs that emit blue color. However, the present disclosure is not limited thereto, that is, the color filters **410** may realize various colors.

FIG. 7 is a schematic cross-sectional view of an organic light-emitting display apparatus **50** according to yet another embodiment of the present disclosure. In FIG. 7, like reference numerals denote like elements in FIG. 5, and thus, descriptions thereof will be omitted.

Referring to FIG. 7, when the organic light-emitting display apparatus **50** is compared with the organic light-emitting display apparatus **30** of FIG. 5, the organic light-emitting display apparatus **50** further includes color filters **410** and a polarizing layer **600**.

The color filters **410** are disposed corresponding to the OLEDs that define the light-emitting regions. The color filters **410** may be formed to realize a full-color image, to increase in color purity, and to increase ambient contrast ratio (ACR). In the drawing, the color filters **410** are formed on a lower surface of the encapsulation substrate **200**, but the present disclosure is not limited thereto. The color filter **410** may be configured to the same as the color filters **410** of FIG. 6.

The polarizing layer **600** is formed to prevent reduction of contrast due to external light by blocking the external light incident from the outside. The polarizing layer **600** may be a circular polarizing plate, a linear polarizing plate, or a combination of these polarizing plates.

In the current embodiment, the OLEDs are formed on the planarizing layer **107**. However, the present disclosure is not limited thereto, that is, may be applied to a type in which the OLEDs are formed on the gate insulating layer **103** or the interlayer insulating layer **105**, or the auxiliary layer **101**.

While the organic light-emitting display apparatuses **10**, **20**, **30**, **40**, and **50** according to the present invention have been particularly shown and described with reference to exemplary embodiments thereof, it will be understood by

those of ordinary skill in the art that various changes in form and details may be made therein without departing from the spirit and scope of the present disclosure as defined by the following claims.

What is claimed is:

1. An organic light-emitting display apparatus comprising: a display substrate; a plurality of organic light-emitting devices (OLEDs) that are disposed on the display substrate and are separated by a pixel defining layer;
- a protective layer disposed on each of the OLEDs;
- an encapsulation substrate that is disposed facing the display substrate and covers the OLEDs;
- a filling material that is disposed between the display substrate and the encapsulation substrate and disposed corresponding to the pixel defining layer,
- an encapsulating member that combines the display substrate with the encapsulation substrate and is disposed to surround the OLEDs, and
- a moisture absorbent disposed on a side of the OLEDs, wherein the filling material includes a material that absorbs visible light, and the filling material protrudes toward the pixel defining layer and surrounds each of the OLEDs and the protective layer on the each of the OLEDs, and
- wherein the moisture absorbent is located between the encapsulation member and the filling material.
2. The organic light-emitting display apparatus of claim 1, wherein the filling material comprises at least one of a black pigment, a black dye, and black particles.
3. The organic light-emitting display apparatus of claim 1, wherein the filling material comprises at least one of methyl silicone and phenyl silicone.
4. The organic light-emitting display apparatus of claim 1, wherein the filling material comprises at least one selected from the group consisting of Cr, CrO, Graphite, and C.
5. The organic light-emitting display apparatus of claim 1, further comprising a color filter disposed corresponding to the OLED on the encapsulation substrate.
6. The organic light-emitting display apparatus of claim 1, further comprising cavities that are disposed between the display substrate and the encapsulation substrate and are disposed corresponding to the OLED, wherein the cavities are filled with air or N₂ gas.
7. The organic light-emitting display apparatus of claim 1, further comprising a protective layer disposed on the OLEDs.
8. The organic light-emitting display apparatus of claim 1, further comprising a polarizing layer disposed on the encapsulation substrate.
9. The organic light emitting display apparatus of claim 1, wherein the moisture absorbent comprises silica gel or phosphorus pentoxide or a combination thereof.
10. An organic light-emitting display apparatus, comprising: a display substrate;
- a display unit that is formed on the display substrate and comprises a plurality of light-emitting regions on which OLEDs are disposed and non-light-emitting regions that separate the light-emitting regions;
- a protective layer disposed on each of the OLEDs;
- an encapsulation substrate that is disposed facing the display substrate;
- a filling material that is disposed between the display substrate and the encapsulation substrate and is disposed corresponding to the non-light-emitting regions,

- an encapsulating member that combines the display substrate with the encapsulation substrate and is disposed to surround the OLEDs, and
- a moisture absorbent disposed on a side of the OLEDs, wherein the filling material performs as a black matrix that absorbs visible light, wherein the filling material protrudes toward the non-light-emitting regions and surrounds each of the light-emitting regions and the protective layer on the each of the OLEDs, and
- wherein the moisture absorbent is located between the encapsulation member and the filling material.
11. The organic light-emitting display apparatus of claim 10, wherein the non-light-emitting regions protrude more than the light-emitting regions.
 12. The organic light-emitting display apparatus of claim 10, wherein the filling material is not formed on the light-emitting regions.
 13. The organic light-emitting display apparatus of claim 10, wherein the filling material is formed of an insulating material that includes a black pigment, a black dye, or black particles.
 14. The organic light-emitting display apparatus of claim 10, further comprising a color filter disposed corresponding to the OLEDs on the encapsulation substrate.
 15. The organic light-emitting display apparatus of claim 10, further comprising a protective layer on the OLEDs.
 16. A method of manufacturing an organic light-emitting display apparatus, the method comprising: forming a patterned filling material on a surface of an encapsulation substrate;
 - forming a display unit on a surface of a display substrate comprising OLEDs;
 - forming a protective layer disposed on each of the OLEDs; and
 - combining the display substrate with the encapsulation substrate with an encapsulating member by disposing the display substrate and the encapsulation substrate so that the display substrate faces the filling material,
 - the filling material surrounds the protective layer on each of the OLEDs and is comprised of at least one of a black pigment, a black dye, and black particles;
 - and further comprising forming a moisture absorbent between the encapsulation member and the filling material before combining the display substrate with the encapsulation substrate.
 17. The method of claim 16, wherein the display unit is divided into light-emitting regions on which OLEDs are disposed and non-light-emitting regions that separate the light-emitting regions and the filling material is patterned to be disposed only on regions of the display unit corresponding to the non-light-emitting regions.
 18. The method of claim 16, wherein the filling material comprises at least one of methyl silicone and phenyl silicone.
 19. The method of claim 16, wherein the filling material comprises at least one selected from the group consisting of Cr, CrO, Graphite, and C.
 20. The method of claim 16, wherein the forming of the patterned filling material comprises: distributing at least one of a black pigment, a black dye, and black particles in a liquid phase filling material;
 - coating the liquid phase filling material on the encapsulation substrate; and
 - patterning the filling material through an exposure and developing process.
 21. The method of claim 20, further comprising hardening the liquid phase filling material.

22. The method of claim 16, wherein the combining of the display substrate with the encapsulation substrate further comprises:

- coating the encapsulating member to surround edges of the filling material; and 5
- combining the display substrate with the encapsulation substrate by using the encapsulating member in a vacuum state by disposing the display substrate and the encapsulation substrate so that the display substrate faces the filling material. 10

23. The method of claim 16, wherein the display unit is divided into light-emitting regions on which OLEDs are disposed and non-light-emitting regions that separate the light-emitting regions, and the method further comprises forming a color filter in regions of the encapsulation substrate that corresponds to the light-emitting regions. 15

* * * * *

专利名称(译)	有机发光显示装置及其制造方法		
公开(公告)号	US9196872	公开(公告)日	2015-11-24
申请号	US13/873645	申请日	2013-04-30
[标]申请(专利权)人(译)	三星显示有限公司		
申请(专利权)人(译)	三星DISPLAY CO. , LTD.		
当前申请(专利权)人(译)	三星DISPLAY CO. , LTD.		
[标]发明人	SON JUNG HYUN NAM KIE HYUN		
发明人	SON, JUNG-HYUN NAM, KIE-HYUN		
IPC分类号	H01L51/00 H01L51/52 H01L27/32		
CPC分类号	H01L51/5284 H01L27/3246 H01L51/525 H01L51/0024 H01L51/524 H01L27/32 H01L27/322 H01L51/5259 H01L51/56		
优先权	1020130003141 2013-01-10 KR		
其他公开文献	US20140191203A1		
外部链接	Espacenet USPTO		

摘要(译)

提供一种有机发光显示装置，包括显示基板；多个有机发光器件（OLED），设置在显示基板上并由像素限定层隔开；封装基板，面向显示基板设置并覆盖OLED；填充材料设置在显示基板和封装基板之间，并且对应于像素限定层设置，其中填充材料包括吸收可见光的材料和制造有机发光显示装置的方法。

